



Features

- Bushing mount
- Sealable
- Non-standard features and specifications available
- Optional high torque feature
- Optional center tap feature
- Gangable

3500/3501 - Precision Potentiometer

Electrical Characteristics ¹	3500 Wirewound Element	3501 Hybritron [®] Element
Standard Resistance Range.....	50 to 200 K ohms	1 K to 200 K ohms
Total Resistance Tolerance.....	±3 %	±10 %
Independent Linearity.....	±0.20 %	±0.25 %
Effective Electrical Angle	3600 ° +10 °, -0 °	3600 ° +10 °, -2 °
Absolute Minimum Resistance/Minimum Voltage	1 ohm or 0.1 % maximum	0.2 % maximum
	(whichever is greater)	
Noise	100 ohms ENR maximum	Output smoothness 0.1 % max.
Dielectric Withstanding Voltage (MIL-STD-202, Method 301)		
Sea Level	1,500 VAC minimum	1,500 VAC minimum
70,000 Feet	400 VAC minimum.....	400 VAC minimum
Power Rating (Voltage Limited By Power Dissipation or 325 VAC, Whichever Is Less)		
+70 °C	2 watts.....	2 watts
+125 °C	0 watt.....	0 watt
Insulation Resistance (500 VDC)	1,000 megohms minimum.....	1,000 megohms minimum
Resolution.....	See recommended part nos	Essentially infinite
Environmental Characteristics ¹		
Operating Temperature Range	+1 °C to +125 °C.....	+1 °C to +125 °C
Storage Temperature Range	-65 °C to +125 °C	-65 °C to +125 °C
Temperature Coefficient Over		
Storage Temperature Range ²	±50 ppm/°C maximum/unit	±100 ppm/°C maximum/unit
Vibration	20 G.....	20 G
Wiper Bounce	0.1 millisecond maximum	0.1 millisecond maximum
Total Resistance Shift	±2 % maximum.....	±2 % maximum
Voltage Ratio Shift	±0.1 % maximum	±0.1 % maximum
Shock	100 G.....	100 G
Wiper Bounce	0.1 millisecond maximum	0.1 millisecond maximum
Total Resistance Shift	±2 % maximum.....	±2 % maximum
Voltage Ratio Shift	±0.1 % maximum	±0.1 % maximum
Load Life.....	1,000 hours, 2 watts	1,000 hours, 2 watts
Total Resistance Shift	±2 % maximum.....	±5 % maximum
Rotational Life (No Load)	2,000,000 shaft revolutions ²	4,000,000 shaft revolutions
Total Resistance Shift	±5 % maximum.....	±5 % maximum
Moisture Resistance (MIL-STD-202, Method 103, Condition B)		
Total Resistance Shift	±2 % maximum.....	±5 % maximum
IP Rating.....	IP 65	IP 65
Mechanical Characteristics ¹		
Stop Strength.....	67.8 N-cm (96 oz.-in.) minimum	
Mechanical Angle.....	3600 ° +10 °, -0 °	
Torque (Starting & Running).....	0.42 N-cm (0.6 oz.-in.) maximum	
Mounting	170-200 N-cm (15-18 lb.-in.) maximum	
Shaft Runout.....	0.05 mm (0.002 in.) T.I.R.	
Lateral Runout	0.13 mm (0.005 in.) T.I.R.	
Shaft End Play	0.13 mm (0.005 in.) T.I.R.	
Shaft Radial Play	0.08 mm (0.003 in.) T.I.R.	
Pilot Diameter Runout	0.05 mm (0.002 in.) T.I.R.	
Backlash.....	1.0 ° maximum	
Weight.....	Approximately 28 gm	
Terminals.....	Gold-plated solder lugs or turrets (see Product Dimensions)	
Soldering Condition		
Manual Soldering	96.5Sn/3.0Ag/0.5Cu solid wire or no-clean rosin cored wire; 370 °C (700 °F) max. for 3 seconds	
Wave Soldering.....	96.5Sn/3.0Ag/0.5Cu solder with no-clean flux; 260 °C (500 °F) max. for 5 seconds	
Wash processes.....Not recommended	
Marking	Manufacturer's name and part number, resistance value and tolerance, linearity tolerance, wiring diagram, and date code.	
Ganging (Multiple Section Potentiometers)2 cups maximum	
Hardware.....	One lockwasher (H-37-2) and one mounting nut (H-38-2) is shipped with each potentiometer.	

Recommended Part Numbers

Part Number	Resistance (Ω)	Resolution
3500S-1-102L	1,000	.030
3500S-1-502L	5,000	.018
3500S-1-103L	10,000	.019
3500S-2-102L	1,000	.030
3500S-2-502L	5,000	.018
3500S-2-103L	10,000	.019

Part Number	Resistance (Ω)
3501H-1-102L	1,000
3501H-1-502L	5,000
3501H-1-103L	10,000

BOLDFACE LISTINGS ARE IN STOCK AND READILY AVAILABLE THROUGH DISTRIBUTION.

FOR OTHER OPTIONS CONSULT FACTORY.

RoHS IDENTIFIER:
L = COMPLIANT
BLANK = NON-COMPLIANT

*RoHS Directive 2002/95/EC Jan 27 2003 including Annex
Specifications are subject to change without notice.

Customers should verify actual device performance in their specific applications.

3500/3501 - Precision Potentiometer

Product Dimensions

3500S

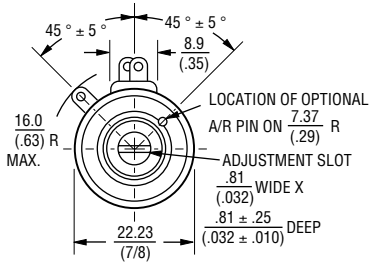
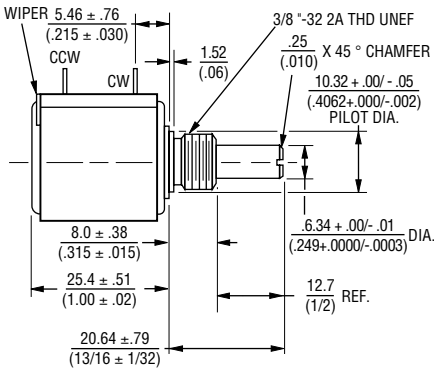

NOTE: SHAFT LENGTH VARIATIONS

3500S-1-RC	$\frac{11}{16}$ (17.46)	(plastic bushing)
3500S-2-RC	$\frac{13}{16}$ (20.64)	(metal bushing)
3501H-1-RC	$\frac{13}{16}$ (20.64)	(metal bushing)

TOLERANCES: EXCEPT WHERE NOTED

DECIMALS: .XX ± $\frac{.25}{.010}$, .XXX ± $\frac{.13}{.005}$

FRACTIONS: ± 1/64

DIMENSIONS: $\frac{MM}{(IN.)}$

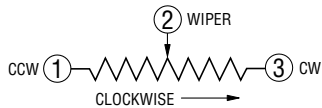

3501H

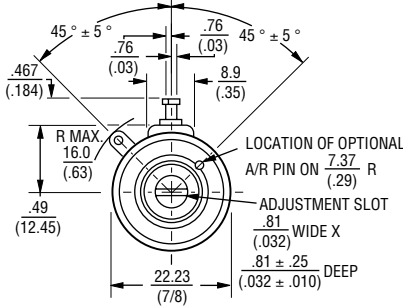
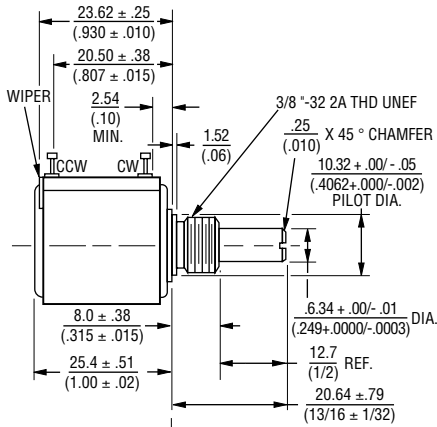

Panel Thickness Dimensions

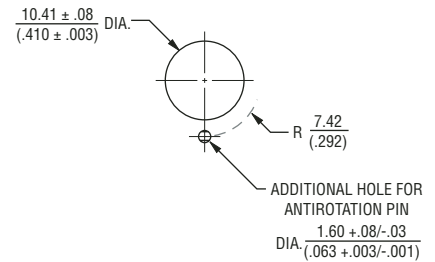
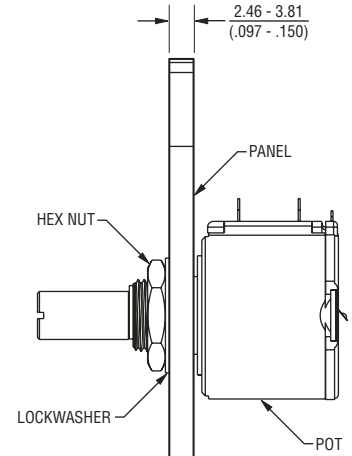

DIMENSIONS: $\frac{MM}{(INCHES)}$

TOLERANCES: ± $\frac{0.127}{(.005)}$